

FEATURES

- Single-channel isolated signal-conditioning modules.**
- Accepts outputs from, millivolt, volt and process current signals.**
- Complete microcomputer-based data acquisition systems.**
- Can be remotely reconfigured for various sensor types and input ranges.**

APPLICATIONS

- Process Monitoring & Control**
- Test Stand Automation**
- Machine Monitoring**
- Material Testing**
- Remote Energy Mangement**
- Laboratory Data Acquisition**

PRODUCT OVERVIEW

The 6B Series delivers sensor-to-host signal-conditioning for remote applications. Software-configurable for a wide variety of sensor types, including: analog input, analog output, and digital I/O, the 6B Series is intended for remote data acquisition, machine monitoring, remote energy management and process monitoring and control applications.

Including transformer-based isolation, ranging, linearization, A/d conversion and RS-232C/RS-485 serial communication for up to 256 channels per serial port, the 6B Series modules and boards are a complete, low-cost interface between computers and analog signals.

All 6B Series input/output modules are fully encapsulated and identical in pin-out and size, facilitating their ability to be mixed and matched with all other 6B Series modules on the same backplane. The 6B Series is fully rated over the industrial temperature range of -25°C to +85°C.

Each 6B Series module and board is a complete microcontroller-based process monitoring and control system, with all calibration, address and linearizing parameters stored in non-volatile memory. Being microcontroller-based, 6b Series

modules can be configured for various sensor types, including RTD and thermocouple, and a wide variety of input ranges. This reduces the number of different modules that need to be used in a given application and carried in inventory.

FUNCTIONAL BLOCK DIAGRAM

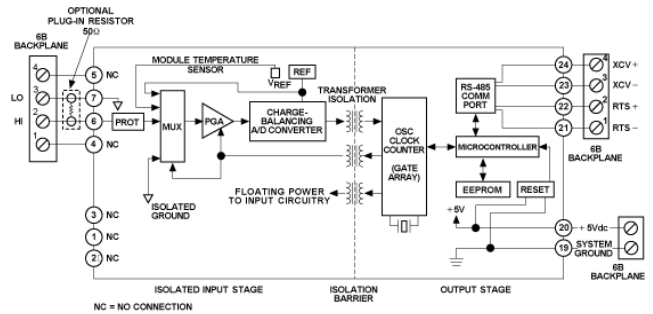

Figure 1. 6B12 & 6B12HV Functional Block Diagram

Designed for industrial applications, the 6B Series modules incorporate transformer-based isolation with surface-mount manufacturing technology – providing increased reliability at low cost. The compact, rugged 6B Series analog modules can be mixed and matched on a 16-channel backplane for high density, remote process monitoring and control.

Communications between backplanes, modules and host is in ASCII over an RS-232C link or RS-485 bi-directional serial bus. Circuitry to convert RS-232C to RS485 is built into the 6B backplane. Baud rates are software programmable, with speeds up to 19.2 K Baud.

The 6B Series digital subsystem communication is compatible with the overall 6B Series communication protocol. Each digital I/O board can be configured for its address, baud rate and checksum status. Connection to the 16 and 24-channel solid state relay backplanes is by a 50-conductor ribbon cable. This enables interfacing with input and outputs from 4 V to 240 V. Power control modules are also available that can switch up to 3A and come with a variety of ratings for low voltage DC up to 280 VAC.

Rev. 0

Information furnished by Analog Devices is believed to be accurate and reliable. However, no responsibility is assumed by Analog Devices for its use, nor for any infringements of patents or other rights of third parties that may result from its use. Specifications subject to change without notice. No license is granted by implication or otherwise under any patent or patent rights of Analog Devices. Trademarks and registered trademarks are the property of their respective companies.

GENERAL DESCRIPTION

The 6B12 and 6B12HV are single-channel isolated signal-conditioning modules which receive milli-volt, voltage and process current signals. Unlike conventional signal conditioners, the 6B12 and 6B12HV are complete microcomputer-based data acquisition systems. A major advantage of the on-board microcontroller is its ability to be reconfigured for various sensor types and input ranges.

Synchronized Sampling – The synchronized sampling command allows data to be sampled simultaneously from all 6B11, 6B11HV, 6B12, 6B12HV modules and all 6B50 boards in a 6B Series system. Each module or board stores the data in a separate register within its microcontroller and can access the data with a separate command.

Software Configuration – The 6B12 and 6B12HV digitize milli-volt and voltage ranges from ± 150 mV to ± 50 V as well as 0 to ± 20 mA process current inputs. Software is used to configure

the 6B12 and 6B12HV modules for address, input range, baud rate data format, checksum status and integration time. All programmable parameters are stored in the nonvolatile memory of the module.

Each analog input signal is conditioned and scaled by a programmable-gain amplifier and digitized by a 16-bit integrating converter under microprocessor control. The digitized value is passed serially across a magnetically isolated barrier (1500 V rms – Model 6B12, 2500 V rms – Model 6B12HV) and clocked in by a custom controller chip. The on-board microprocessor then converts the data into engineering units as determined by the channel parameters. In between conversions, the microprocessor auto zeros the offset and gain by monitoring the on-board temperature and compensating for reference drift. Cold junction compensation (CJC) is also performed at this stage. The 6B12 and 6B12HV use compensation factors to ensure the highest accuracy possible.



Figure 2

Models 6B12 and 6B12HV

Range Description (Software Configurable)	Accuracy (Typical)	Error (Maximum)	Noise (Peak-to-Peak)
±150 mV	±0.03 % FS	±0.06 % FS	±0.02 % FS
±500 mV	±0.01 % FS	±0.04 % FS	±0.008 % FS
±1 V	±0.006 % FS	±0.03 % FS	±0.007 % FS
±5 V	±0.006 % FS	±0.03 % FS	±0.006 % FS
±10 V	±0.006 % FS	±0.03 % FS	±0.005 % FS
±50 V	±0.006 % FS	±0.03 % FS	±0.004 % FS
±20 mA ¹	±0.006 % FS ²	±0.03 % FS ²	±0.007 % FS

¹ This range requires the use of a 50 Ω current-to-voltage conversion resistor, model AC1381.

² Does not include the error of the current-to-voltage input resistor, Model AC1381.

6B12 and 6B12HV Specifications (typical @ +25°C and V_s = +5 V dc)

Description	Model 6B12 and 6B12HV
Inputs, Software Selectable	
Voltage Ranges	
mV	±150 mV; ±500 mV
Volt	±1 V; ±5 V; ±10 V; ±50 V
Current Range	±20 mA
Communications	
Protocol	RS-485
Baud Rates, Software Selectable	300K, 600K, 1.2K, 2.4K, 9.6K, 19.2K
Accuracy	
Initial @ +25°C	Refer to Model Table
Input Offset vs. Temperature	±0.3 μV/°C
Span vs. Temperature	±10 ppm/°C (±50 ppm/°C, maximum)
Input Resistance	1 M Ω
Bandwidth, -3 dB	4 Hz
Conversion Rate	9 samples /second
Synchronized Sampling Command	Yes
Conversion Time	70 ms maximum
Common-Mode Voltage (CMV)	
Input-to-Output and Power	
Model 6B12	1500 V rms, continuous
Model 6B12HV	2500 V rms, continuous
Common-Mode Rejection (CMR)	
1 k Ω Source Imbalance @ 50/60 Hz	108 dB

1 k Ω Source Imbalance @ 50/60 Hz

56 dB

Input Protection

240 V rms, continuous

Input Transient Protection

ANSI/IEEE C37.90.1-1989

Power Supply

Voltage, Operating

+5 V dc \pm 5%

Voltage, maximum safe limit

+6.5 V dc

Current

+100 mA

Mechanical Dimensions2.3" x 3.1" x 0.79"
(58.4 mm x 78.7 mm x 19.1 mm)**Environmental**

Temperature Range

Rated Performance

-25°C to +85°C

Operating

-25°C to +85°C

Storage

-40°C to +85°C

Relative Humidity

0 to 95% @ +60°C non-condensing

¹ When used with the CJC temperature sensor, model AC1361, provided on each channel of 6B Series backplanes. Specifications subject to change without notice.

PIN CONFIGURATIONS AND FUNCTIONAL DESCRIPTIONS

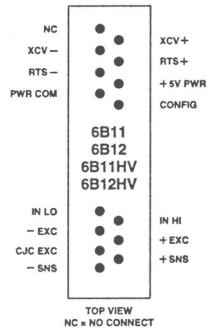

Figure 3 . Model 6B Series Module, with pin-out assignments.

Table 1. Pin Function Descriptions—

Pin No.	Description
1	N/C
2	HI
3	LO
4	N/C

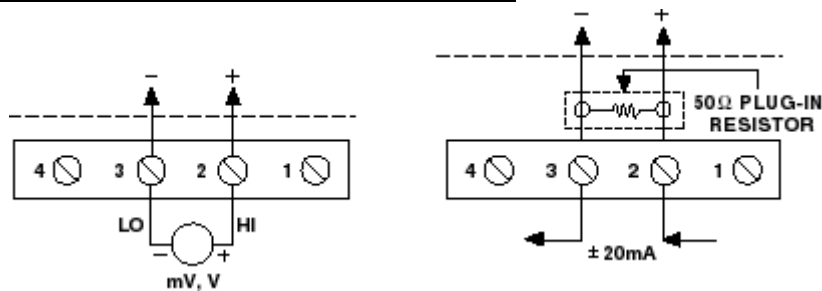

Figure 4 6B12 & 6B12HV Input Field Connections

ESD CAUTION

ESD (electrostatic discharge) sensitive device. Electrostatic charges as high as 4000 V readily accumulate on the human body and test equipment and can discharge without detection. Although this product features proprietary ESD protection circuitry, permanent damage may occur on devices subjected to high energy electrostatic discharges. Therefore, proper ESD precautions are recommended to avoid performance degradation or loss of functionality.



OUTLINE DIMENSIONS

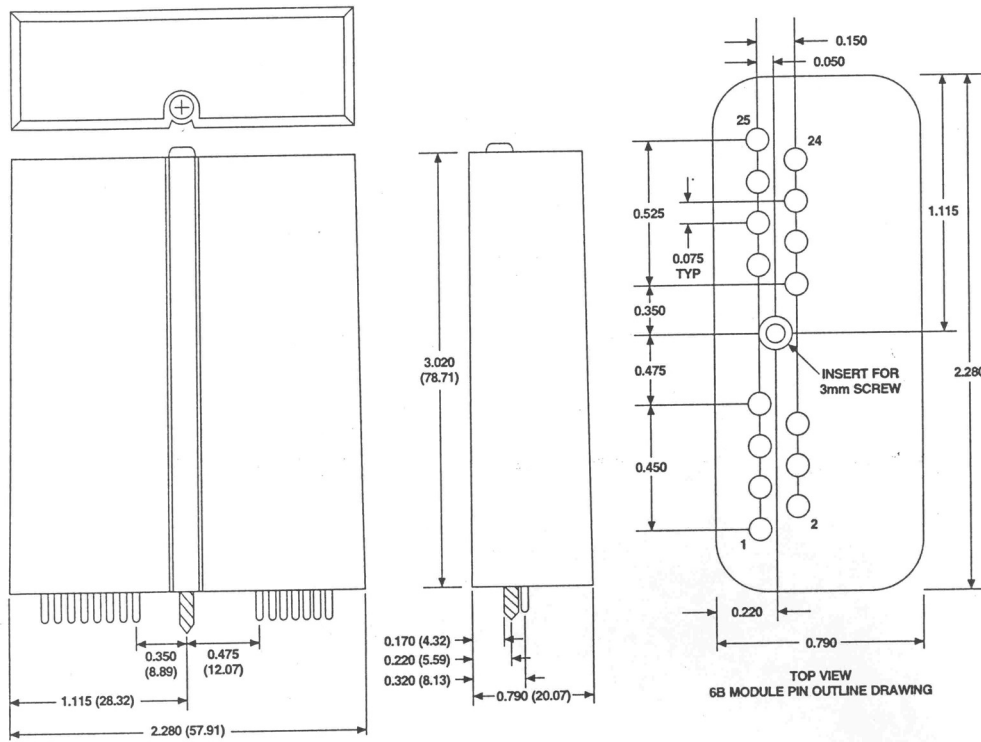

Figure 5. Outline Dimensions

NOTES

NOTES

6B12
6B12HV

The height dimension of the module specified on page 6 indicates 3.020 inches & 78.71mm. The mm dimension does not match the dimension in inches. Change the mm dimension to (76.71).

Baud Rate (page 3) indicates 300K, 600K, 1.2K, 2.4K, 9.6K, 19.2K, The 300K should be just 300, the 600K should be just 600, Add 4.8K to the list of baud rates